

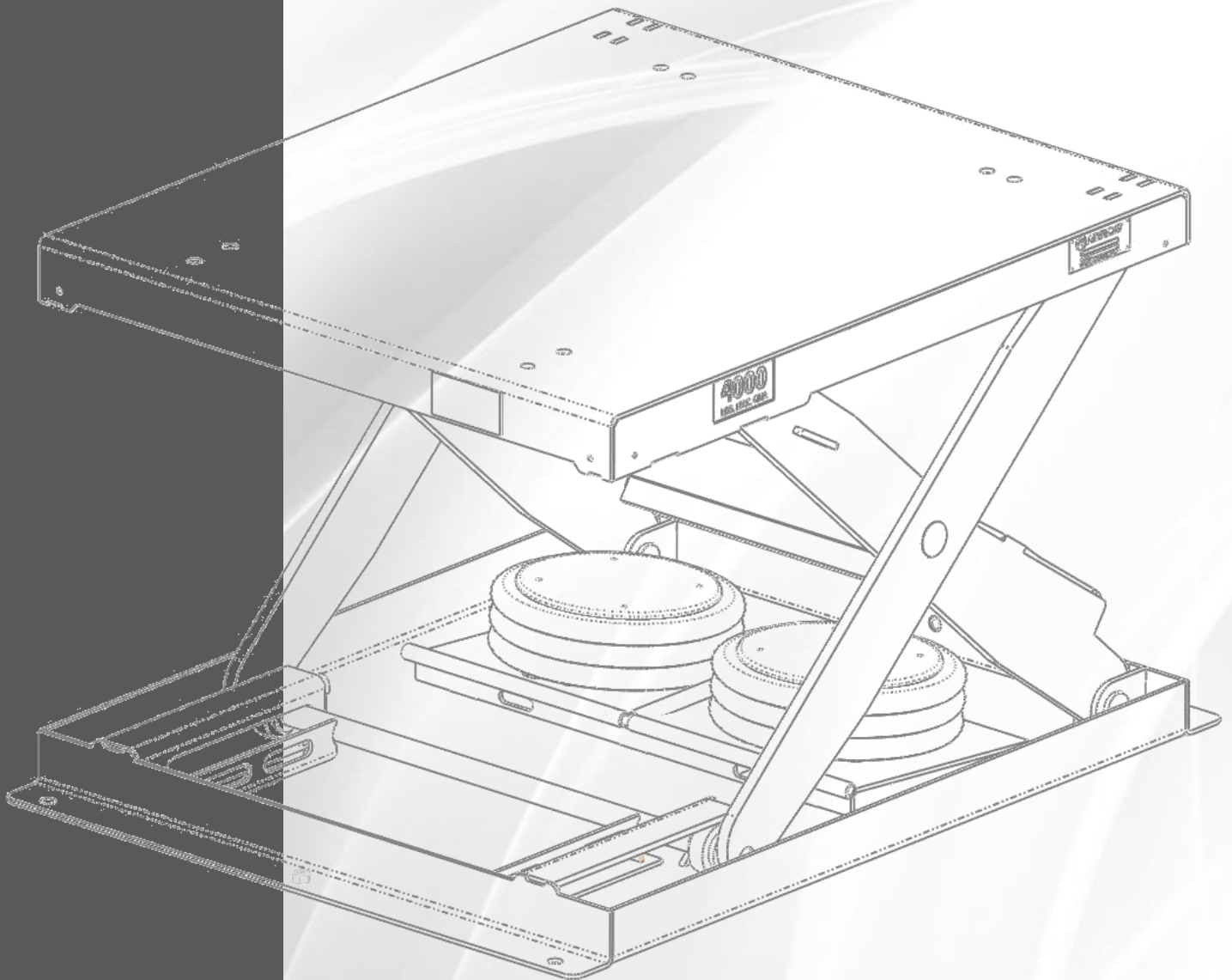

Standard Operating Manual Pneumatic Lift Tables



ADDRESS

2230 Brush College Road

Decatur, IL 62526

Phone: 217-423-6001

Fax: 217-422-1049

E-mail: sales@alignprod.com

www.Alignproductionsystems.com



Table of Contents

I. Description of Equipment	4
II. Specifications	4
III. Set-Up Instructions	4
IV. Operating Information	5
V. Service & Maintenance	5
VI. Troubleshooting	6
VII. Spare Parts	6
VIII. Limited Warranty	7

I. Description of Equipment

This equipment consists of an air-spring pneumatic lift table. The unit comes complete with one hand- or foot-activated valve for raising and lowering the lift table. A safety block is included inside the base of the lift. The block is used during service and maintenance of the unloaded unit.

II. Specifications

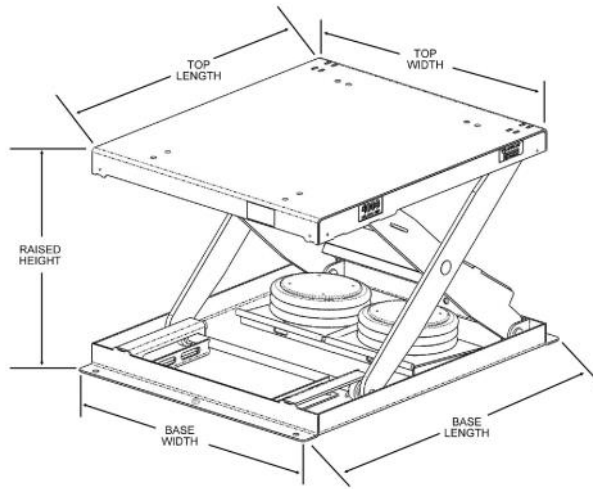

Model Number	Load Capacity	Base Size W x L	Raised Height	Lowered Height	Travel	Top Size W x L
ST010-3648	2,000 lbs.	36" x 48"	32 $\frac{1}{4}$ "	8 $\frac{1}{4}$ "	24"	36" x 48"
ST011-4248	4,000 lbs.	42" x 48"	32 $\frac{1}{4}$ "	8 $\frac{1}{4}$ "	24"	42" x 48"
ST012-4848	6,000 lbs.	48" x 48"	36"	12"	24"	48" x 48"
ST013-4848	8,000 lbs.	48" x 48"	36"	12"	24"	48" x 48"
ST014-4350*	6,000 lbs.	43" x 50"	28"	4"	24"	43" x 50"
ST014-2448*	2,000 lbs.	24" x 48"	32 $\frac{1}{4}$ "	8 $\frac{1}{4}$ "	24"	24" x 48"

* Special low-profile (ST014-4350) and/or narrow-top (ST014-2448) models. Consult factory for more information.

III. Set-Up Instructions

1. Position lift table on floor at desired location.
2. Un-band all associated components (e.g., control valve stand, dirt leg, etc.) and position at own discretion. Foot control valves may be placed loose on the floor with air lines neatly placed on floor to prevent tripping hazards. Hand control valve assemblies and dirt leg assemblies will require securing to the floor or column, respectively.
3. Connect $\frac{1}{2}$ " diameter air line to valve.

IV. Operating Information

Raising and Lowering Unit

1. **To Raise the Unit:** Activate control valve. Hold lever until desired height is reached or until lift table has reached its maximum stroke and release valve.
2. **To Lower the Unit:** Activate control valve to lower the table until it has reached its minimum stroke.
3. **Air Pressure Adjustment:** On the lift is a pressure-regulating valve that has been preset at the factory to 100 PSI to prevent over-pressurization of the air spring. **DO NOT READJUST POSITION.**

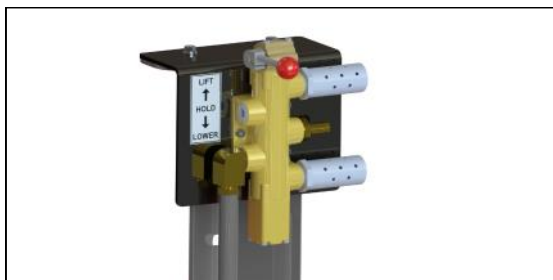

v. Service and Maintenance

To Replace Air Spring on Lift (Unloaded Unit Only)

1. Raise platform to full height.
2. Remove safety skirt and place maintenance block between scissor mech. and frame.
3. Drain air line to table and lock out.
4. Remove air plumbing and eight (8) $\frac{3}{8}$ " cap screws securing air spring top and bottom.
5. To reinstall, reverse the above procedure.

Maintenance blocks



VI. Troubleshooting

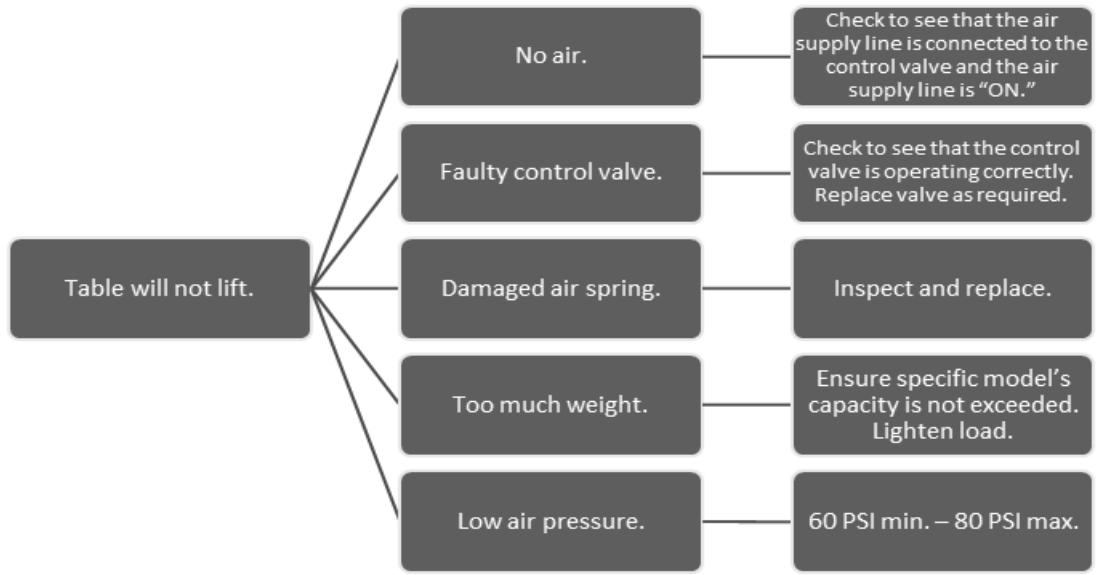

VII. Spare Parts

Lift Table Model	Air Spring	Debris Skirt
ST010-3648	ASPF7842	ST5010-0010
ST011-4248	ASPF7842	ST5010-0020
ST012-4848	ASPF7842	ST5010-0030
ST013-4848	ASPF7842	ST5010-0030
ST014-4350	ASPOBR65	ST5010-0040
ST014-2448	ASPF7842	ST5010-0050

To reorder a part, please call **1-800-888-0018** and ask for the Parts Department. If possible, please have your equipment serial number handy for reference.





Limited Warranty

Align Production Systems (APS) warrants all of its products to be free of defects in material and workmanship for a period of one (1) year from date of shipment to the original purchaser or 2,000 operating hours, whichever comes first, provided purchaser gives APS prompt notice of the alleged defect(s) and, if requested by APS, returns the defective items, freight prepaid (F.O.B. APS's plant in Decatur, Illinois).

THE WARRANTIES SET FORTH HEREIN ARE IN LIEU OF ALL OTHER WARRANTIES, WHETHER EXPRESS OR IMPLIED, INCLUDING, WITHOUT LIMITATION, FITNESS FOR A PARTICULAR PURPOSE AND MERCHANTABILITY, ALL OF WHICH ARE EXPRESSLY DISCLAIMED.

For any claim under warranty, APS may elect to repair or replace the defective component or components. All claims for warranty must be accompanied by a Return Goods Authorization number, which may be obtained from APS. This warranty does not cover, and APS is not responsible for, any labor or other expense for inspections, removal or reinstallation of components or products.

This warranty does not cover, among other things, damages resulting from foreign matter or water, negligence, accident, unreasonable use, abuse or misuse, alterations not authorized by APS, failure to provide reasonable and necessary maintenance or failure to follow operating instructions or load limits.

IN ADDITION, IN NO EVENT SHALL APS BE LIABLE FOR ANY SPECIAL, INDIRECT, INCIDENTAL, CONSEQUENTIAL OR CONTINGENT DAMAGES, WHETHER OR NOT IT HAS BEEN ADVISED OF THE POSSIBILITY OF SUCH DAMAGES.

APS makes no representation that the product complies with local, state or federal safety/product standards codes. If the product fails to comply in any way with those codes, it shall not be considered a defect in materials or workmanship, and APS shall not be liable for any damages resulting from noncompliance. This limited warranty is provided to the original purchaser (meaning the original end user) and is nontransferable. This limited warranty constitutes the complete and final agreement regarding APS warranty obligations for the product.