

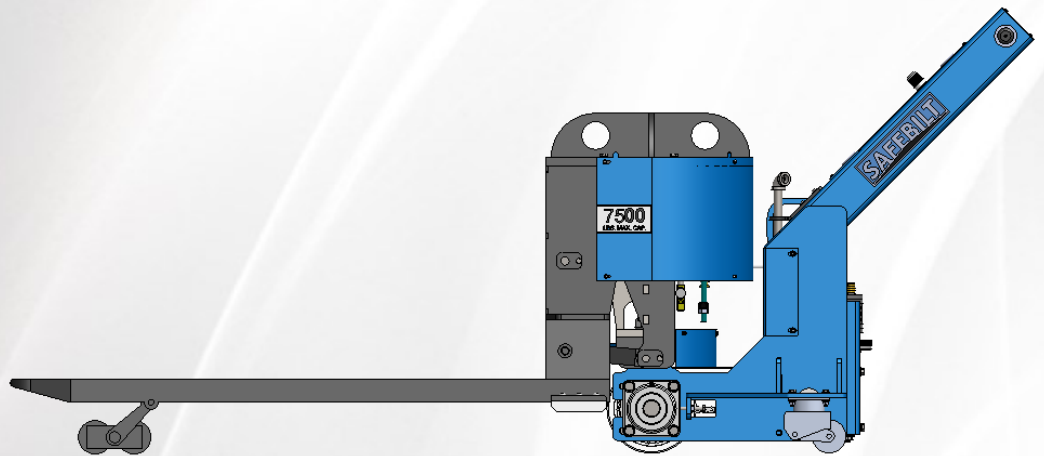

STANDARD OPERATING MANUAL

PNEUMATIC HIGH CAPACITY PALLET JACK

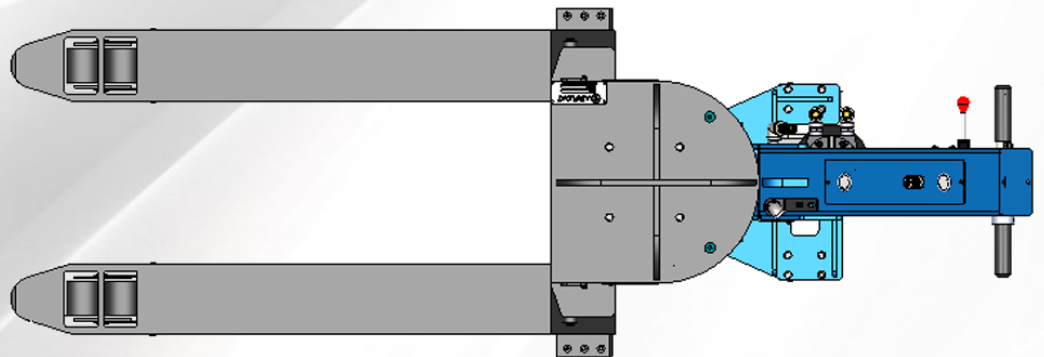

ADDRESS

2230 Brush College Road

Decatur, IL 62526

Phone: 217-423-6001

Fax: 217-422-1049

E-mail: sales@alignprod.com

WWW.ALIGNPRODUCTIONSYSTEMS.COM

TABLE OF CONTENTS

I. Description of Equipment	4
II. Specifications	4
III. Reference Drawings	4
IV. Operating Information	4
V. Typical Operating Sequence	5
VI. Service and Maintenance	6
VII. Recommended Spare Parts	7
VIII. Troubleshooting Guide	7
IX. Limited Warranty	8

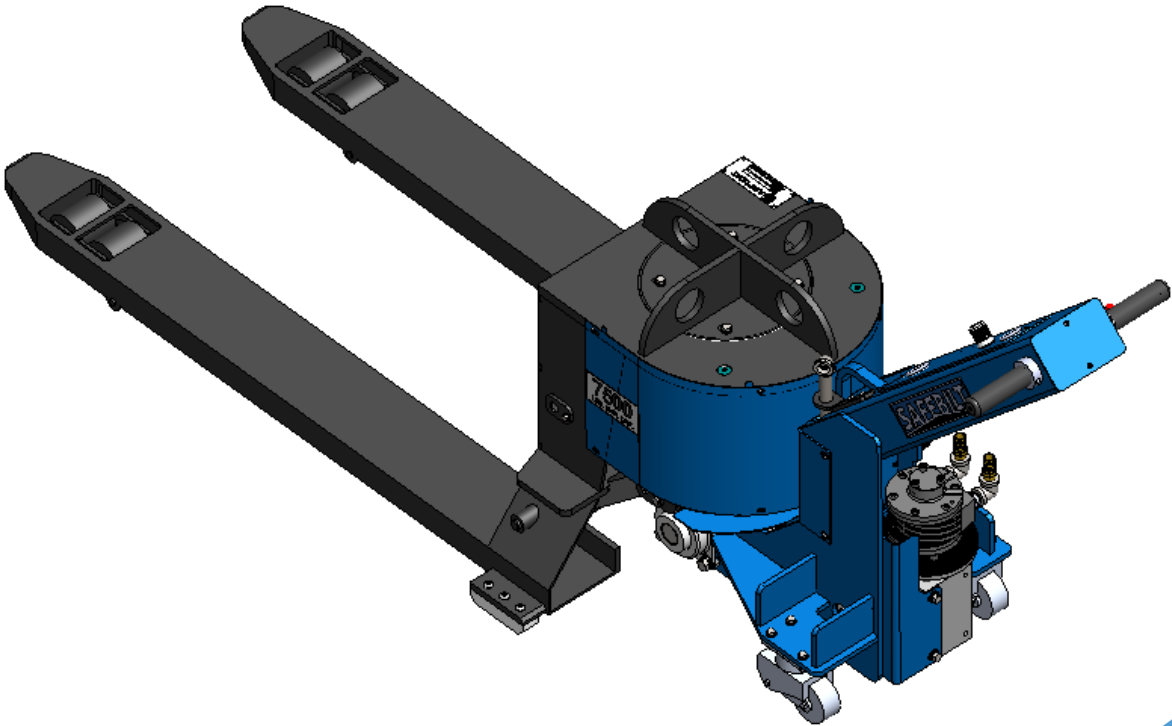

I. DESCRIPTION OF EQUIPMENT

This pallet jack was designed primarily for movement of palletized loads weighing up to 7,500 lbs. The drive unit contains an air motor, speed reducer and drive wheel mounted on a pivoting bracket, which allows 150° steering.

II. SPECIFICATIONS

Model Number	Capacity	Speed (variable with adjustable max.)	Air Supply Pressure	Air Consumption
ST040-7500	7,500 lbs.	0 – 50 FPM	90 PSI	45 SCFM

III. REFERENCE DRAWINGS

ST040-7500	Pneumatic high capacity pallet jack, capacity: 7500 lbs., lower fork height: 3", raised fork height: 6.75"
ASY0045	Pallet truck drive assembly
ASY0056	Pallet truck lift assembly
PSC1779	Pneumatic schematic for pallet jack

IV. OPERATING INFORMATION

The operator should become familiar with the following controls and their adjustments.

LIFT CONTROLS

This valve raises and lowers the top weldment of the pallet jack. When standing at the operating position push the hand level down or away from your position. The valve is detented in the down direction so once the valve has been actuated, the load will lower and will not stop. To stop the load from lowering, actuate the valve in the up direction by pulling the hand lever toward the operator. To raise the pallet jack top weldment, hold the hand lever in the up direction by pulling the lever toward the operator. You will need to hold the hand lever until the desired height or the up hard stop has been met.

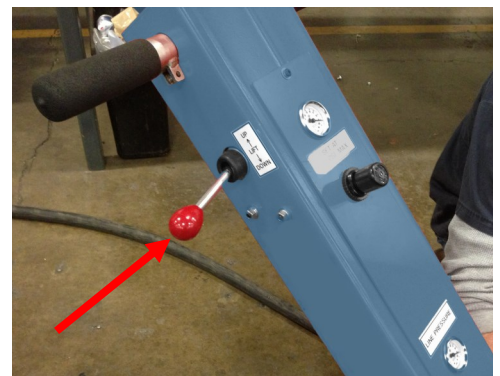

IV. OPERATING INFORMATION (CONT.)

DRIVING THE PALLET JACK

The pallet jack can be driven by using the twist handle. The twist handle controls the direction of the drive wheel as well as the speed of movement of the drive. The greater the degree of twist on the handle, faster the speed. To travel forward grip the twist handle and rotate forward, opposite movement for reverse.

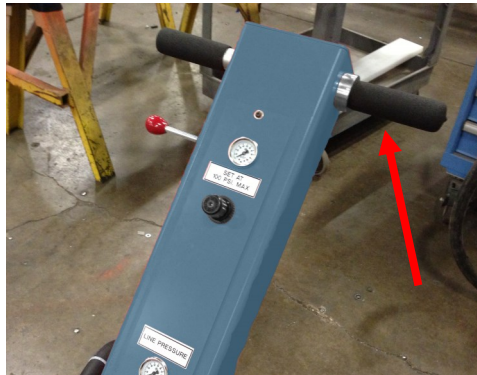

STEERING THE PALLET JACK

Steering is controlled by manually moving the entire drive steering handle to one side of the other while the unit is moving.

V. TYPICAL OPERATING SEQUENCE

1. Connect main air supply to the pallet jack.
2. Drive the pallet jack into position of the load, aligning the centerline of the pallet jack with the center line of the load.
3. Drive the pallet jack under the load until the load is resting against the back plate.
4. Actuate the hand lever to raise the pallet jack. Hold the hand lever until the load has been lifted off of the ground. The pallet jack will raise approximately 3 ¾" or 7,500 lbs., whichever comes first.
5. Rotate the twist grip to control the speed and direction of the desired pallet jack movement.
6. Once the pallet is moved to the desired location, deactivate the air spring by moving the hand lever forward.
7. When the air spring has completely exhausted, drive the pallet jack back from beneath the load.

VI. SERVICE AND MAINTENANCE

For good air motor life, Align Production Systems recommends that the air supply must be filtered with a five-micron filter and be free of water.

For good air motor life, Align Production Systems recommends that the air supply must be filtered with a five-micron filter and be free of water.

Check the gearbox oil level periodically and replace with lubricant recommended by speed reducer manufacturer. (See serial number tag on gearbox.)

Every two months lubricate pallet and drive wheel grease zerks with MPG grease.

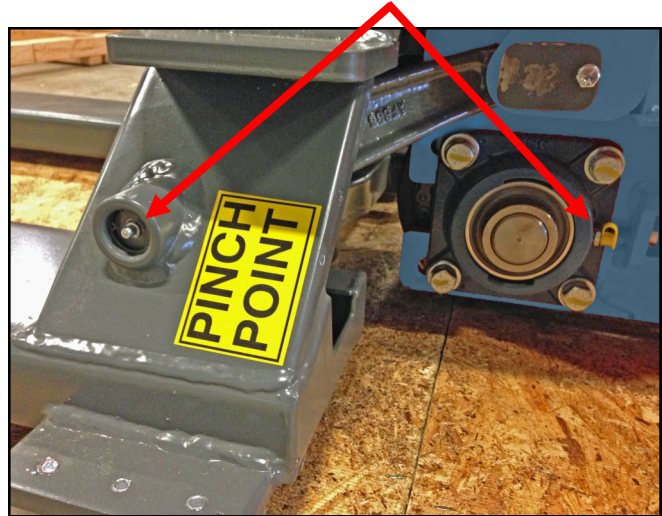

VII. RECOMMENDED SPARE PARTS

Qty.	Part Number	Description
1	BRGTM0010	Bearing cup
1	BRGTM0012	Bearing cone
1	WHL0248	Drive wheel
2	BRGMC5967K880	Drive wheel bearings
1	VSD8007	Lift hand-twist valve
1	RENGG04001	Air spring regulator
1	VHU-QE2	Air spring quick exhaust valve
1	SRDAD001	Gear reducer
1	AMT0001	Drive air motor
1	VVA-VAL3203111	Air spring lift handle lever valve

VIII. TROUBLESHOOTING

Problem	Cause	Remedy
Load doesn't lift or lifts but doesn't move easily.	Supply hose quick disconnect too restrictive.	Increase the size of quick disconnect if used on the system.
	Supply hose too small for its length.	Increase hose size.
	Load is too heavy.	Try lighter load.
	Load is too heavy.	Increase air pressure up to 100 PSI .
When rotated the twist grip handle fails to actuate drive.	—	Check for loose or broken push-pull rod inside of handle tube. Remove covers on the handle tube to inspect.
Drive wheel stalls when load is moved.	—	Insufficient air supply to drive motor. Check the pressure gauge stating "line pressure." This pressure should not be less than 70 PSI.
Drive wheel rotates but slips excessively.	Floor surface may be oily or too steep for pallet jack.	Verify by reducing load or testing on different floor locations.
Pallet jack fails to lift load from floor.	Lift air spring regulator may be set too low.	Increase air spring regulator on handle tube up to 100 PSI.



LIMITED WARRANTY

Align Production Systems (APS) warrants all of its products to be free of defects in material and workmanship for a period of one (1) year from date of shipment to the original purchaser or 2,000 operating hours, whichever comes first, provided purchaser gives APS prompt notice of the alleged defect(s) and, if requested by APS, returns the defective items, freight prepaid (F.O.B. APS's plant in Decatur, Illinois).

THE WARRANTIES SET FORTH HEREIN ARE IN LIEU OF ALL OTHER WARRANTIES, WHETHER EXPRESS OR IMPLIED, INCLUDING, WITHOUT LIMITATION, FITNESS FOR A PARTICULAR PURPOSE AND MERCHANTABILITY, ALL OF WHICH ARE EXPRESSLY DISCLAIMED.

For any claim under warranty, APS may elect to repair or replace the defective component or components. All claims for warranty must be accompanied by a Return Goods Authorization number, which may be obtained from APS. This warranty does not cover, and APS is not responsible for, any labor or other expense for inspections, removal or reinstallation of components or products.

This warranty does not cover, among other things, damages resulting from foreign matter or water, negligence, accident, unreasonable use, abuse or misuse, alterations not authorized by APS, failure to provide reasonable and necessary maintenance or failure to follow operating instructions or load limits.

IN ADDITION, IN NO EVENT SHALL APS BE LIABLE FOR ANY SPECIAL, INDIRECT, INCIDENTAL, CONSEQUENTIAL OR CONTINGENT DAMAGES, WHETHER OR NOT IT HAS BEEN ADVISED OF THE POSSIBILITY OF SUCH DAMAGES.

APS makes no representation that the product complies with local, state or federal safety/product standards codes. If the product fails to comply in any way with those codes, it shall not be considered a defect in materials or workmanship, and APS shall not be liable for any damages resulting from noncompliance. This limited warranty is provided to the original purchaser (meaning the original end user) and is nontransferable. This limited warranty constitutes the complete and final agreement regarding APS warranty obligations for the product.