

REVISIONS				
ZONE	REV.	DESCRIPTION	DATE	REV. BY

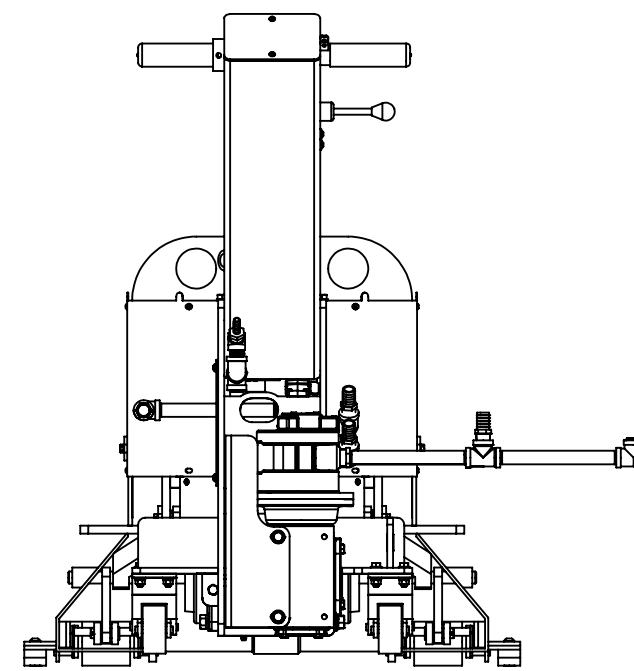
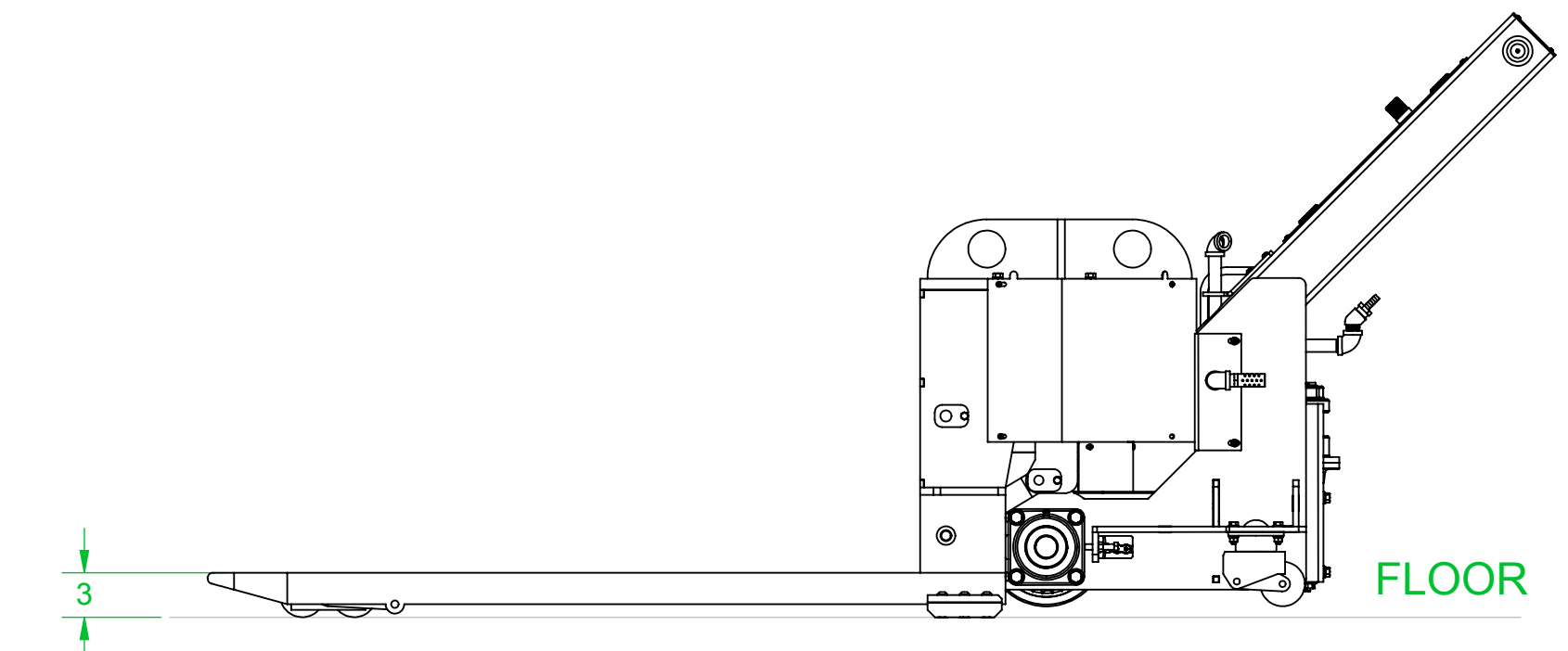
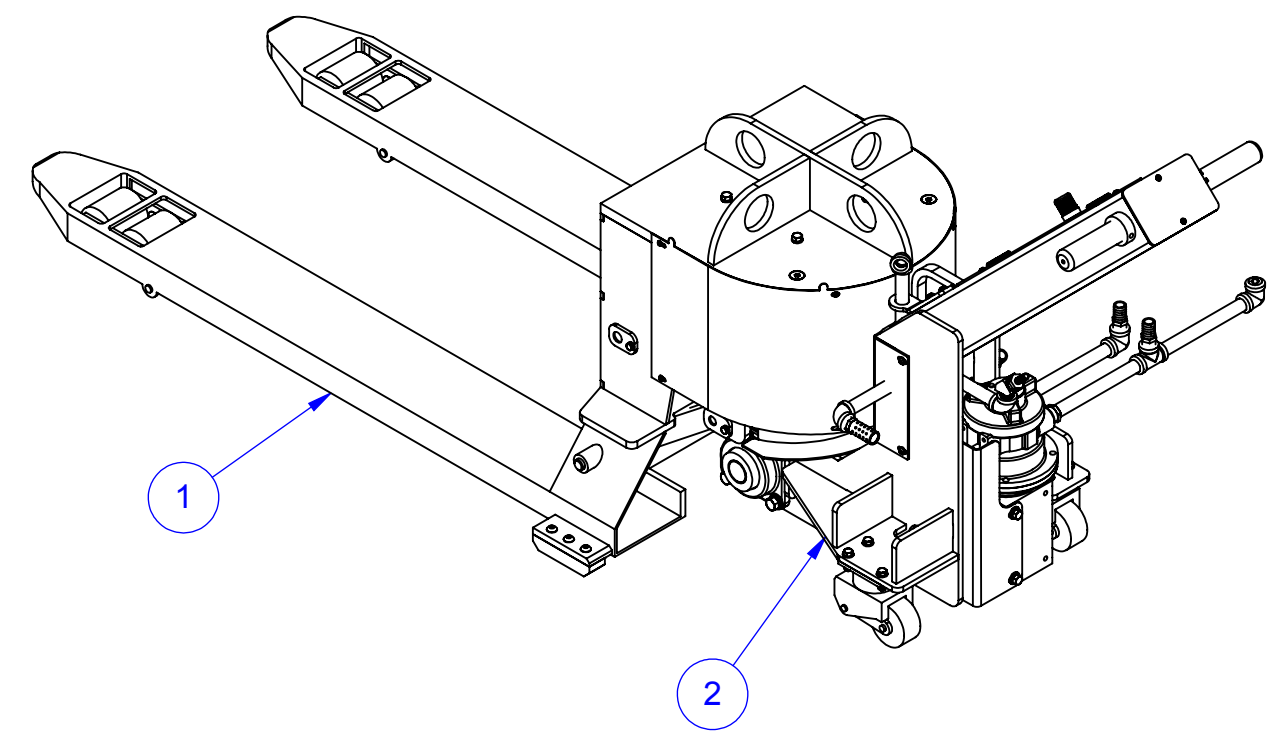
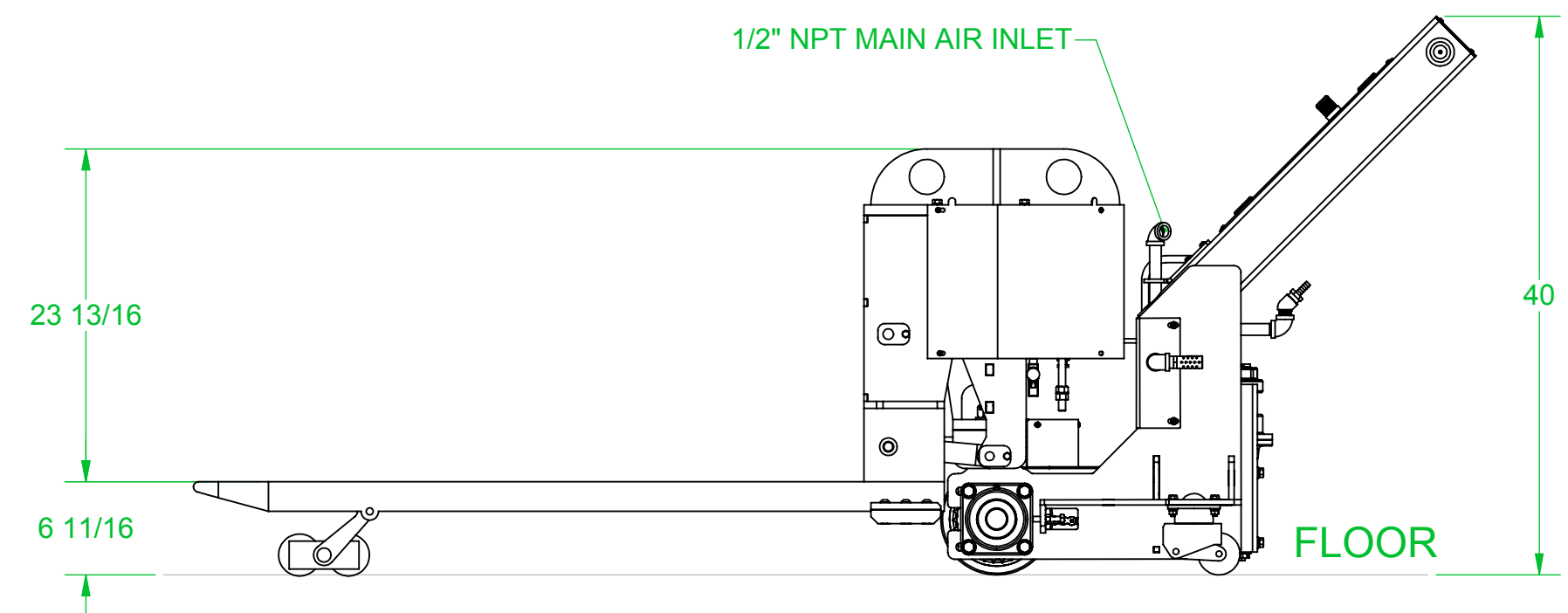
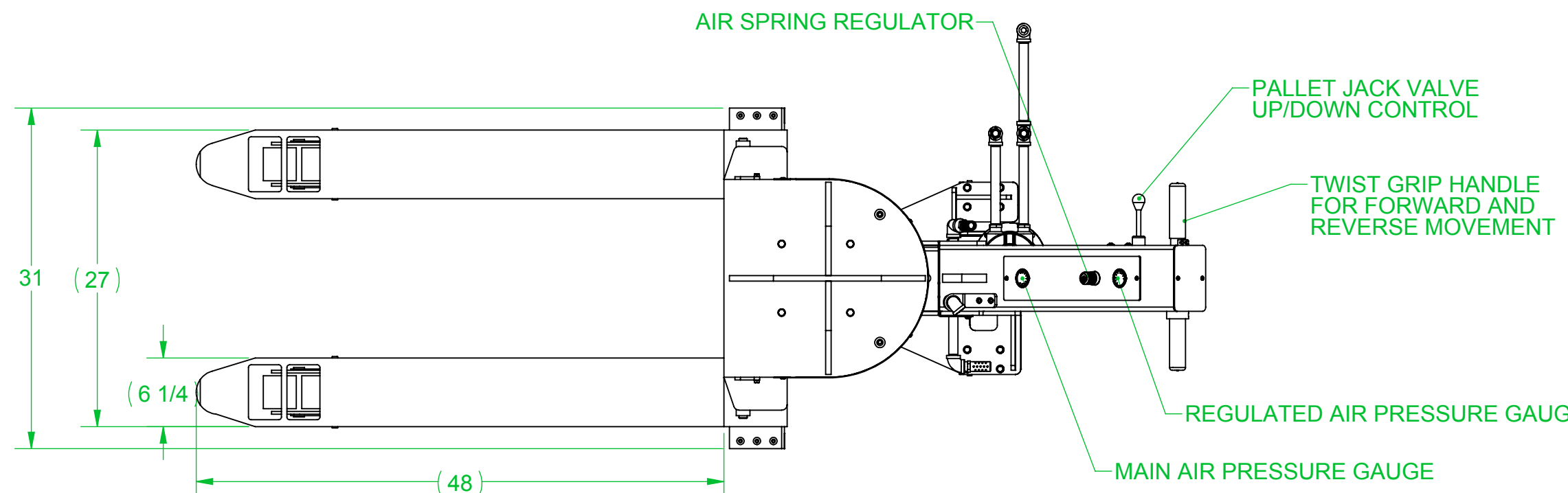

**SPECIFICATIONS:**  
 CAPACITY: 7500 LBS  
 AIR CONSUMPTION 45 SCFM  
 AIR PRESSURE 90 PSI  
 AIR TO BE OIL FREE, DRY AND CLEAN  
 (5 MICRON OR LESS)  
 AIR CONNECTION 1/2" NPT  
 FORK DIMENSIONS 27" x 48"  
 LOWERED FORK HEIGHT 3"  
 RAISED FORK HEIGHT 6-3/4"  
 PAINT AIRFLOAT GREY / RED

QTY.	SYM.	PART NUMBER	NOMENCLATURE OR DESCRIPTION	MATERIAL SPEC.	WIDTH	LENGTH	ROUTING	WEIGHT
1	3	PSC1779	PNEUMATIC SCHEMATIC FOR PALLET JACK				A	0
1	2	ASY0045	PALLET TRUCK DRIVE ASSEMBLY				A	154.23
1	1	ASY0056	PALLET TRUCK LIFT ASSEMBLY				A	352.89

DISCARD ALL DRAWINGS AND/OR BILL OF MATERIALS ISSUED PRIOR TO  
**9/5/2014**  
 USE PRINT WITH THE LATEST DATE FOR PRODUCTION  
 ENGR. APPROVAL

UNLESS OTHERWISE SPECIFIED DIMENSIONS ARE IN INCHES TOLERANCES ARE:  
 FRACTIONS: .XX ± .03  
 DECIMALS: .XXX ± .010  
 ANGULAR: ± 1°  
 DO NOT SCALE DRAWINGS

WORK ORDER # \_\_\_\_\_ ROUTING **A**

DRAWN PAB 2/25/13

TOTAL WT. 507.11 lbs SHEET 1 OF 1 SIZE C SCALE 1:12

THIS DRAWING CONTAINS INFORMATION PROPRIETARY TO ALIGN PRODUCTION SYSTEMS LLC AND SHALL NOT BE DISCLOSED FOR ANY PURPOSE NOR USED FOR MANUFACTURING PURPOSES WITHOUT THE WRITTEN PERMISSION OF ALIGN PRODUCTION SYSTEMS LLC.

ALIGN PRODUCTION SYSTEMS  
 2230 Brush College Rd  
 Decatur, IL 62526  
 www.alignprod.com  
 sales@alignprod.com  
 Phone: 217.423.6001

TITLE **PNEUMATIC HIGH CAPACITY PALLET JACK 7500LBS LOWER FORK HEIGHT 3" RAISED FORK HEIGHT 6.75**

DRAWING NO. **PJS-7.5K-2748** REV. **--04**